

Cape Software Inc.
Training and Competency Management



KNOWLEDGE
MANAGEMENT



Since people are a company's number one asset, the investment in the development of this vital resource pays dividends with increased productivity, improved safety, better employee morale and high retention rates. Part of that investment includes implementing effective training and competency management that ensures that the asset is managed safely and efficiently. Further, it facilitates maximising throughput and ensuring workforce satisfaction and capability.

We offers multiple facets of training and competency management (TCM) solutions that can integrate e-learning programs, traditional classroom methods, computer-based training (CBT), operator training simulation & Operator Training Systems (OTS), Virtual Reality (VR), and operating procedures. We provide our clients with technical knowledge and practical skills so they can make better operational decisions.

Our fit-for-purpose solutions cover a range of needs and budgets to take our client's training needs from the "Essential to Excellence" learning quadrants. Our goal is to help customers mitigate risks and maximise returns while training a confident, competent, and safe workforce.

We serve a broad range of markets as a control system-independent provider of automation & control, digital tools and consultancy services to a variety of sectors and markets including oil and gas, chemicals & refining, power, infrastructure & environmental, mining, industrial & manufacturing, and government.



Our offering

Our's training solutions are designed to facilitate training for improved safety by enabling operators to perform tasks in a simulated environment. Our solutions are designed to help the operators acquire skills to respond to events/scenarios quickly and correctly, facilitate reactions and behaviour changes in high-stress conditions, set standards and guidelines for team training and communications, and develop competency management.

The benefits of our solutions include:

- providing a fully immersive, and safe environment to learn and train
- simulating difficult or dangerous/hazardous scenarios cost effectively and without undue risk to participants
- providing an opportunity for improved knowledge retention and effect behaviour change by repeatedly reevaluating/recreating scenarios
- gaining virtual life experiences and assimilate lessons-learned by living through incidents/conditions and developing proper response habits – *"been there, done that"*...
- reducing the number of abnormal scenarios and unplanned shutdowns
- lowering the risk of loss of life, damage to assets, production and/or environmental releases
- increasing operator awareness, skills and readiness

We recognise that a company's OTS investment can save hundreds of thousands of dollars or more, with return on investment (ROI) realised in a matter of weeks or months. This investment further reduces the company's capital investment costs, increase production yields and facilitates better management decision-making, while leveraging the use of current technology and its infrastructure investments.

Our IP:

- Virtuoso® / VP Link / ProDyn
- ProLearn / ProLMS / OperatorSuite

Connectivity

- Rockwell ControlLogix, AADvance, Trusted, and A-B PLC5/SLC500
- Honeywell Experion PKS, TDC,TPS, FSC, Safety Manager, and Plantscape
- Triconex: Tricon/Trident
- Foxboro I/A, Archestra, InFusion
- Yokogawa Centum VP, CS3000, ProSafe/RS
- Emerson Delta V
- GE Fanuc Series 90, Modicon, Siemens-Ti 505
- ABB Mod300, Advant, Industrial IT
- Siemens APACS, PCS7, S7 etc.

- Hardware signals to any processor and I/O
- Emulation using regulatory control blocks
- 3rd party LMS, DBMS & ERPs
- PI/Historians, Alarm Management Systems & SIS

Typical deliverables:

- E-learning & Learning Management Systems
- Operator Training Simulators
- Training needs analysis and frameworks
- Virtual Reality based training systems
- Classroom curriculums and on-the-job training
- Operating procedures
- Knowledge, skills and performance assessments
- Control/Safety system checkouts

Industries served:

- Upstream Oil and Gas
- Chemicals & Refining
- Food and Beverage
- Nuclear & Power Generation
- Environmental & Mining
- Pharmaceuticals
- Aerospace

We offer E-learning tools that are designed to supplement classroom-based training, enabling students to study and learn at their own pace. Our easy-to-use digital tools are specially designed to deliver E-learning solutions for scientific and engineering disciplines, with its interactive quizzes and web-based operations.

Our E-learning packages offer standardised, structured and engaging training. Our solutions are sharable content object reference model (SCORM compliant). Our systems can also be easily integrated with a client's 3rd party SCORM compliant learning management systems (LMS), if one already exists.

Our solutions are ideal for corporate training centers, continuing education programs, including students and educators in technical colleges/schools. We offer a variety of training modules that focus on providing fundamental understanding of equipment, unit operations and systems found in the various targeted industries.

"It's all to do with the training: you can do a lot if you're properly trained." - Queen Elizabeth II

"I hear and I forget. I see and I remember. I do and I understand."- Confucius

Digital Twins: Operator Training with a twist...

A "digital twin" is a virtual representation of an asset, that can be used from early design and on to building/construction and operations. It is typically maintained and easily accessible throughout its lifecycle. For this purpose, an Operator Training System (OTS) offers a "flight" simulator-style environment for the digital twin of an industrial process, akin to a pilot flying a virtual airplane. The term "simulator" can be used to describe all forms from simple to complex simulators. With an OTS, operators and engineers have a platform to train on, depending on the requirements of their various job tasks. Questions concerning the operations of complex processes and handling various scenarios can be addressed.

The OTS allows the operators to train on a computer system in an environment that's identical to their control room, as the OTS is configured to interface with an offline version of the control system, stimulated with process models. Training scenarios are typically set up by a trainer and repeated as often as necessary, without any

impact on the actual operations or process. There are also opportunities for "free-flight" simulation sessions, to allow the operator to familiarise themselves and get comfortable with the operating environment.

These training scenarios includes operations start-up and shut-down; change of load, product or operating conditions; critical process situations and emergency procedures. In addition, the operating strategies and control & safety logic can be verified, without any undue impact on the ongoing actual operations.

At Cape, we offer these digital twins so the users can gain in-depth process understanding through the use of "fit-for-purpose" fidelity dynamic simulation models of the operations, that aid in performing both process analysis and operator training. Performing dynamic simulation is an essential component of the asset life cycle management, from concept to commissioning, through engineering and design simulations, to operator training, what-if scenarios and continuous plant improvement.

We offer operators an immersive platform to be trained and master their respective processes in a safe and realistic environment without any concerns of damage or disruption to the actual plant operations. In

addition, we offers a large library of pre-built process models, comprehensive trainee performance analytics, and the ability to connect to multiple modelling engines (i.e., Virtuoso®, VP Link, PetroSIM, Hysys and UniSim, etc.) and major control systems, setting it apart from other OTS software.

These user-friendly packages can be hosted on-premises or deployed as cloud-enabled. Our systems are OPC (Open Platform Communications) compliant and are designed to interface with a broad range of 3rd party systems, allowing direct communications with Distributed Control Systems (DCS), Supervisory Control and Data Acquisition (SCADA) / Human Machine Interface (HMI), customer-specific algorithms, and other packages.

We also offers Virtual Reality (VR) and Augmented Reality (AR) packages to facilitate training. We pride ourselves in being in the forefront of delivering OTS packages that go one step further. Our VR and AR implementations utilise the increased computer power to simulate real or imaginary environments and scenarios with a high degree of realism and interactivity. Our solutions replicate not just the control room but the entire operations, including the visual and auditory aspects of the experience.

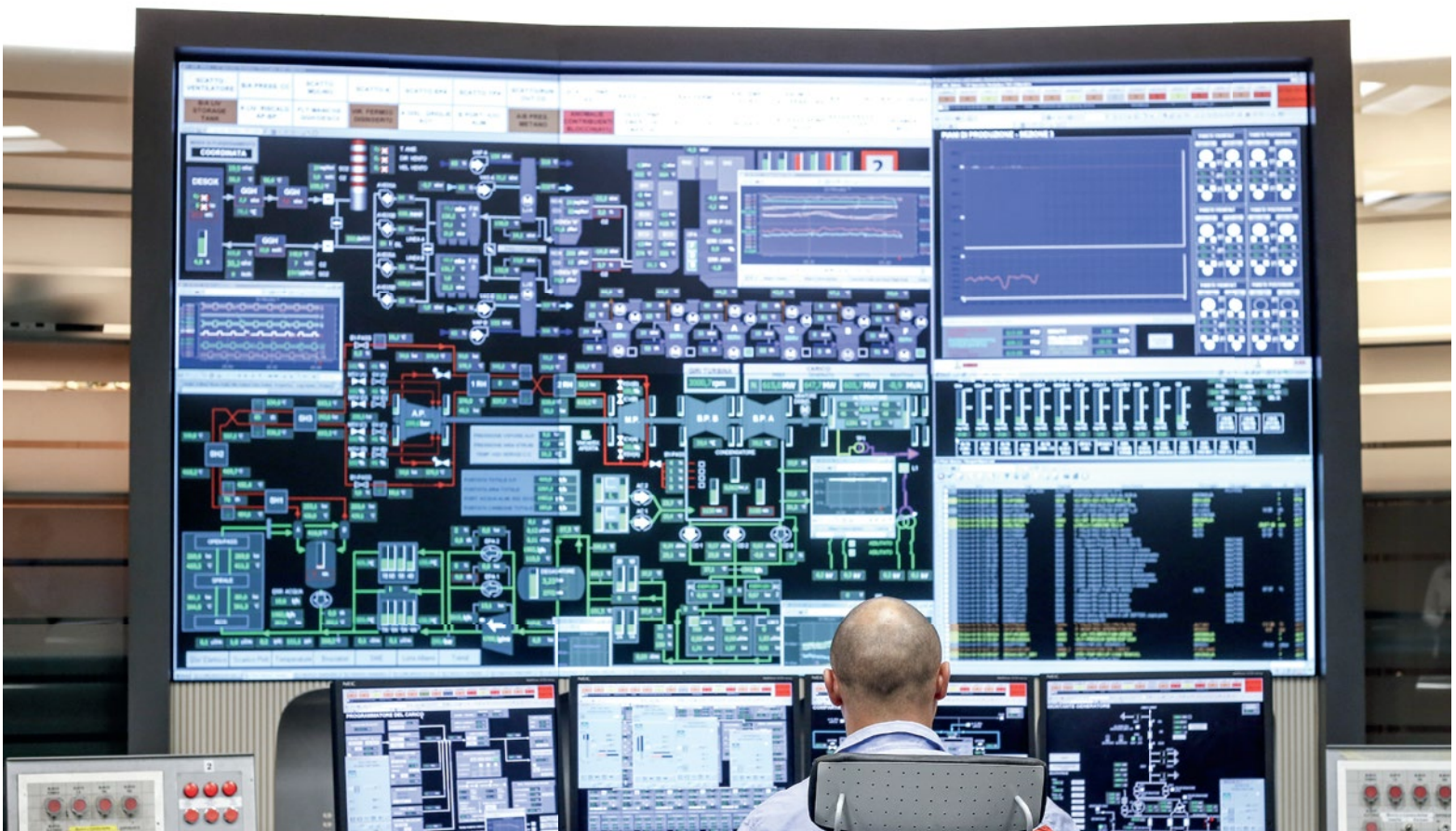

Case Study 1: Offshore Oil & Gas Operations - Middle East

We delivered an Engineering Simulator (ES) and an OTS for this offshore gas gathering asset. The ES is used for performing operations planning and analysis while the OTS is used to evaluate and train users on the operating procedures for the subsea and topsides process systems and responses.

OTS (Operator Training System) features:

- high-fidelity process model for the topsides & subsea
- seamless integration between topsides/subsea/controls/HMI
- OTS model interfaces with the Siemens DCS (PCS7) for the subsea systems and communicates with the Rockwell Automation system (ControlLogix + Wonderware HMI) for the topsides process

ES (Engineering Simulator) features:

- dynamic model of entire production network (i.e., from the wells to the topsides)
- perform complex scenario creation and replay analysis
- component tracking (e.g., CO₂, N₂, etc.)
- perform system capacity and throughput analysis
- conduct analysis of liquids issues and slugging
- hydrate inhibitor distribution, regeneration and tracking

System deployed:

- integrated system using VPLink and Virtuoso

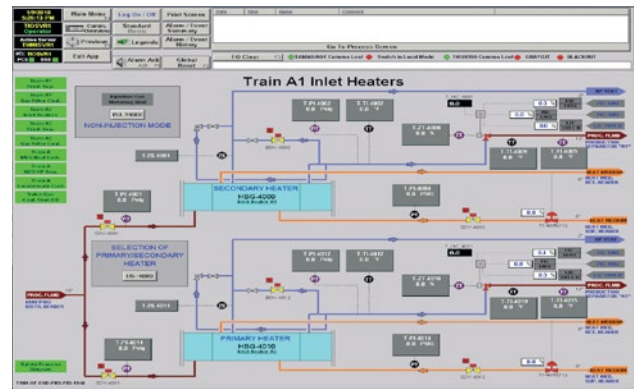
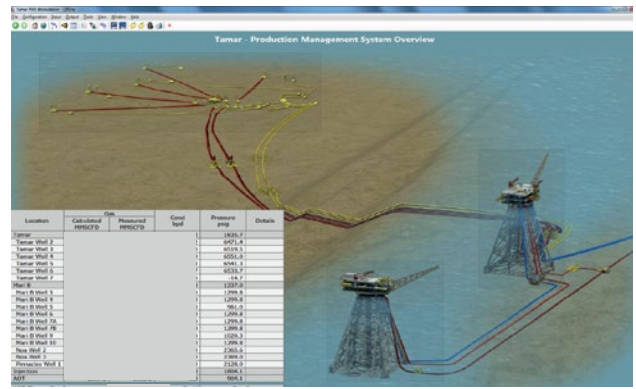

Case Study 2: Offshore Oil & Gas Operations - Gulf of Mexico

We delivered an Engineering Simulator (ES) and an OTS for this offshore oil production and gathering asset. A single-well ES model was initially developed and used to perform a process feasibility assessment. A full-field ES model was then developed and used for performing further design studies. The OTS was then deployed for operator training on the operating procedures for the subsea and topsides process systems and evaluate emergency response.

OTS (Operator Training System) features:

- simulates the subsea production operations and the subsea & topsides controls
- OTS model interfaces with Cameron subsea controls
- OTS also communicates with the Yokogawa Centrum (topside control) and Prosafe

ES (Engineering Simulator) features:

- high-fidelity simulations
- simulates well production and separation in caissons
- simulates gas and oil flow to dedicated risers and flow from the downcomer line
- simulates various topsides components, including the oil processing and oil storage

System deployed:

- integrated system using VPLink and Virtuoso

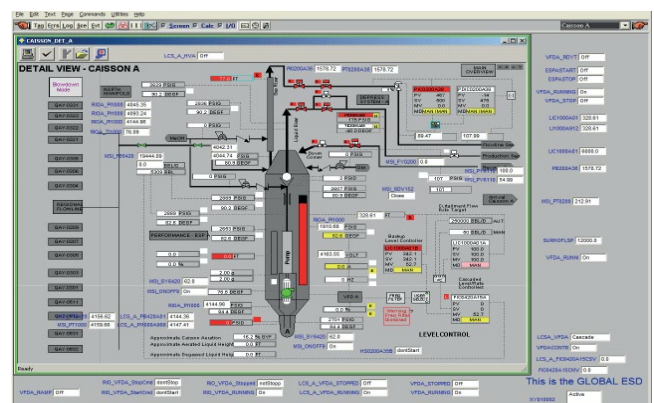
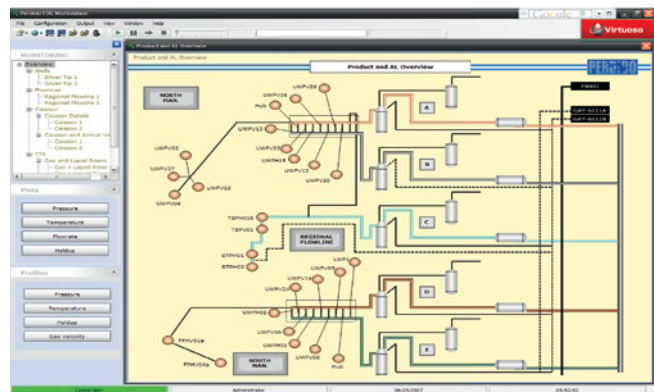

Case Study 3: Offshore Oil & Gas Operations - Gulf of Mexico

We delivered an OTS for this offshore Cap-and-Flow system. Following the Macondo incident in the GoM, there is a need to maintain a high-level of training and competency for personnel tasked in performing cap-containment-flow operations, in the event of a similar event. The OTS is the centerpiece of a rigorous operator training program on the operating procedures for the subsea system and topsides process dynamics.

OTS (Operator Training System) features:

- high-fidelity process model for topsides using VPLink
- high-fidelity subsea model using Virtuoso
- interfaces with a Rockwell Automation ControlLogix
- seamless integration between topsides, subsea, control systems and HMI (human machine interface)
- use of pre-configured training scenarios
- user-friendly fully customisable instructor interface
- ability to select a range of wells/fluids

System deployed:

- integrated system using VPLink and Virtuoso

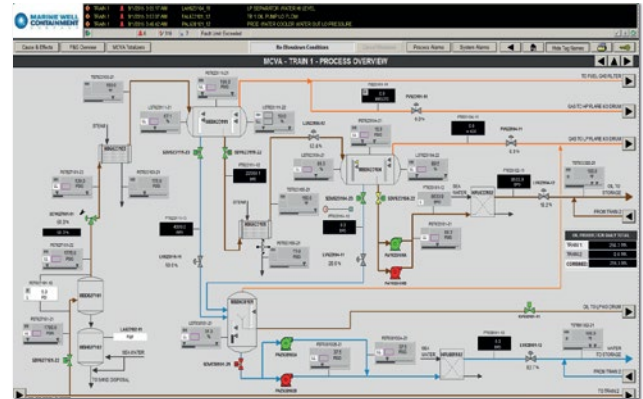
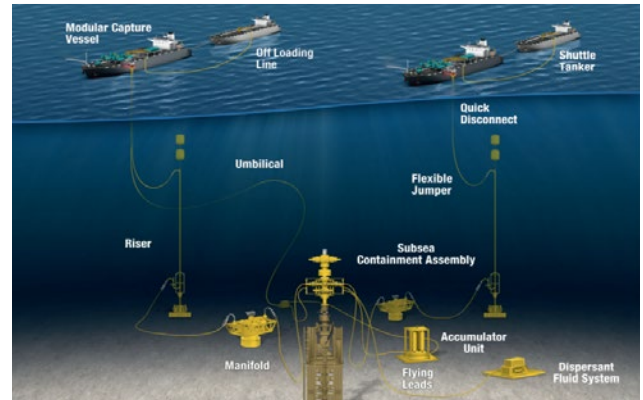

Case Study 4: Refinery Operations - Texas

We delivered a process OTS for this refinery. The OTS is used to familiarise the operators with various upset scenarios, ensuring they can safely bring the plant back to normal operations and minimise downtime when they meet these scenarios in the real plant. The OTS is integrated with a VR-simulator of the plant, allowing the control room operators and field operators to carry out operations simultaneously, just as they would in the real plant. The screens show examples of the Sulfur Recovery Unit (SRU) OTS and one of the VR models for the pumping stations.

OTS (Operator Training System) simulates the following key processes:

- sulfur recovery unit (SRU)
- fluid catalytic converter (FCC)
- crude oil distillation (atmospheric & vacuum units)
- coker unit
- hydrotreaters
- OTS model interfaces with TDC-3000 Controllers and Triconex Safety Instrumented Systems (SIS)

System deployed:

- integrated system using VPLink

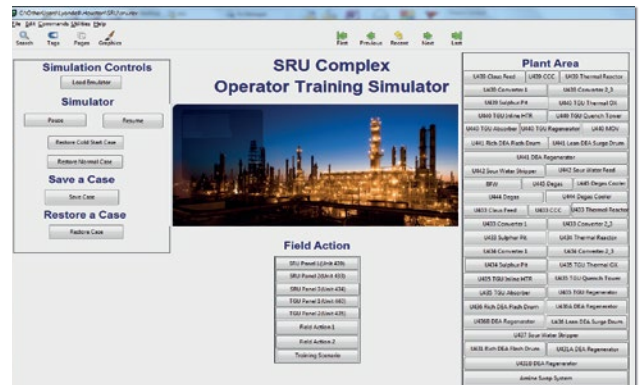

Case Study 5: Recycling Plant Operations - Europe

We delivered a process OTS for this plant that incinerates rubbish in large ovens, using the heat generated to produce steam for turbines and thus generating electricity for thousands of households. The OTS is used to familiarise the operators with the various operations associated with the plant.

OTS (Operator Training System) features:

- high-fidelity process model for combustion, steam generation and wastewater treatment
- interfaces with Rockwell Automation ControlLogix
- OTS delivered with full save/restore/pause/resume functionality with Rockwell Automation Logix Emulate for OTS (first European project to do so)
- pre-configured training scenarios and upset conditions
- scoring engine for quantitative assessment of trainee performance
- fully customisable instructor interface

System deployed:

- integrated system using VPLink

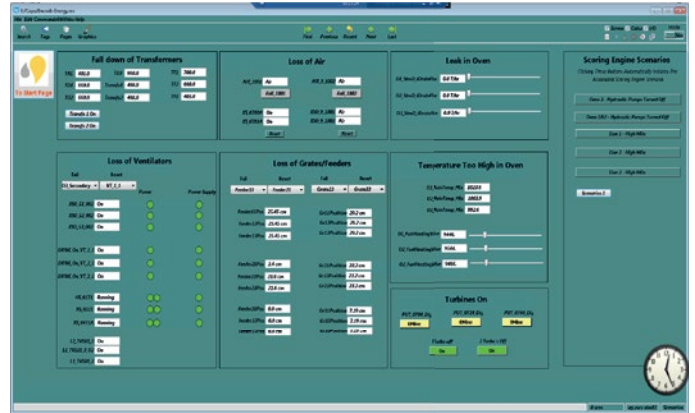
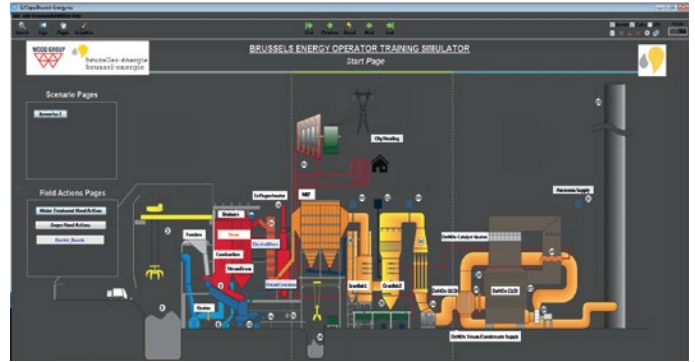

Case Study 6: Crude Distillation Unit - Louisiana

We delivered a hi-fidelity process OTS for the crude distillation unit (CDU) for this plant in Chalmette, LA. The CDU processes both light and heavy crude oil to produce products like LPG, light naphtha, heavy naphtha, kerosene, cracked gas oil, light vacuum gas oil, heavy vacuum gas oil, and vacuum residue.

The OTS is used to familiarise the operators with the various operations associated with the plant.

High-fidelity OTS (Operator Training System) features:

- dynamic modelling of hot and cold preheat trains, five desalters, atmospheric tower, gas oil towers, vacuum distillation unit, three fuel gas fired furnaces, stabilizer, pre-fractionator & wet gas compressors, emergency shutdown system
- replication of actual Honeywell TDC3000 graphics
- key instructor features include snapshots, generic malfunctions, performance monitor, alarms, exercise, and analytics scoring engine for quantitative assessment of trainee performance

System deployed:

- integrated system using ProDyn

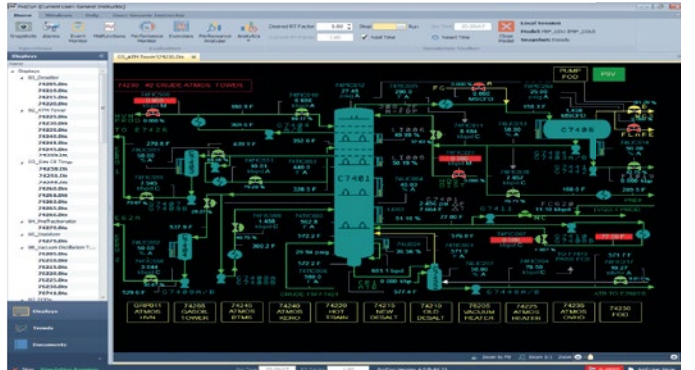

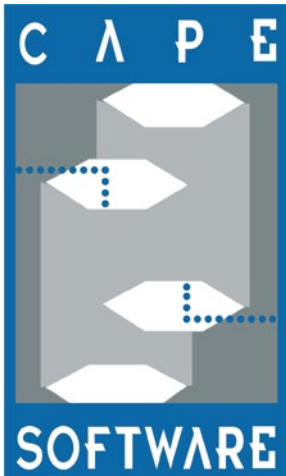

Cape Software is an experienced provider of products and engineering services that are integral for the deployment of immersive and engaging Operator Training Simulator (OTS) systems. We also assist our clients with conducting successful factory acceptance testing (FAT) of their process control system (PCS) and safety instrument system (SIS) logic applications.

capesoftware.com